

## FLAT PANEL SKIRT INSTALLATION INSTRUCTIONS

*PLEASE READ INSTRUCTIONS BEFORE PROCEEDING WITH INSTALLATION*

**NOTE:** The skirt panel may require re-sizing to fit the specific installation. Carefully take your measurements so that the skirt will fit the skirt opening. If re-sizing is required, it is suggested that the skirt is measured and marked to the required dimensions. Cut to within 1/8" of finished dimensions using a fine tooth saw. Use a belt sander to remove the remaining material to the finished size. The skirt could be damaged if improper procedures and/or tools are used. It is important to follow all the steps in this installation procedure. If additional guidance is required, you may contact the Aquatic Technical Department at (800) 928-3707.

### PARTS INCLUDED FOR INSTALLATION:

- 4 - Spring Clips
- 8 - #6, 1/2" self tap screws for spring clips
- 3 - #8, 1 3/4" stainless steel screws  
(use 2 for 5' skirts, 3 for 6' skirts)
- 3 - Chrome decorative caps
- 3 - Brass decorative caps
- 3 - Decorative cap holders
- 9 - Decorative caps in assorted colors with attached cap holders
- 1 - Instruction sheet

### TOOLS REQUIRED FOR INSTALLATION: (NOT INCLUDED)

- Phillips Head Screwdriver
- Belt Sander
- Fine-Tooth Saw
- Wood Blocks
- Pencil
- Safety Glasses
- Square/Level
- Gloves

**If any of the above parts are missing from your package, contact Aquatic Technical Department at (800) 928-3707.**

## FLAT PANEL SKIRT INSTALLATION INSTRUCTIONS

1. Remove the wood strip (on some models) from the structural support. **DO NOT REMOVE** the structural support. **SEE DETAIL VIEW A.**
  2. Locate the raised lip support channel beneath the lip of the bath tub as shown in **FIGURE 1**. **NOTE:** Some models do not have the lip support channel running the full length of the tub. These tubs will need to have blocks of wood glued (construction cement) to the underside of the tub so that the spring clips can be attached.
  3. Place the spring clips at even intervals along the support channel, use all four clips. Position the front of the clip to line up with outside of the Bath Lip, (**SEE FIGURE 4**) making sure they line up properly. Mark the hole openings for the screws with a pencil. Place a #6, 1/2" screw at the marked position and secure the clips to the channel. Use 2 #6 screws for each clip as shown in **FIGURE 1**. Make sure the screws go into the support channel or into the wood blocks.
  4. Slide upper side of skirt (**SEE FIGURE 4**) under the lip of the tub. Align the offset edge of the skirt so it is parallel with the bottom of the bath lip (**SEE FINAL ASSEMBLY**). The panel should slip into place between the lip rim and the four spring clips (**SEE FIGURE 4**). While holding skirt at the bottom, move it inward toward the tub (**SEE FIGURE 2**). The vertical edge of the skirt should be aligned perpendicular to the floor (**SEE FINAL ASSEMBLY**).
  5. **Tubs with ABS Base: SEE FIGURE 3 AND FINAL ASSEMBLY.** To align the skirt so it is perpendicular with the floor, you may need wood shims between the structural support and the ABS Base. Then secure the ABS Support Base with two or three 1 3/4" #8 screws, through the decorative caps and the pre-drilled holes at the base of the skirt (**SEE DETAIL VIEW B**).
- Tubs with Metal Frame Base: SEE FIGURE 2 AND FINAL ASSEMBLY.** To secure the bottom of the skirt, wood blocks (2 for 5' skirts or 3 for 6' skirts), will need to be anchored to the floor. Use a level (that is held against the outside face of the tub lip and touching the floor) at each pre-drilled hole location to mark where the face of the skirt panel will be aligned. Subtract the thickness of the skirt and the structural support to position the wood blocks. Anchor the blocks to the floor, then screw the 1 3/4" #8 screws, through the decorative caps and the pre-drilled holes, into the wood blocks.

## DETAIL VIEW A

ITEM NO.	PART NUMBER	DESCRIPTION	Default/QTY.
1	SKFRT5SE, OR SKFRT6SE	5 OR 6 FOOT SKIRT	1
2	8050PIPE-SKIRT	1/2" STRUCTURAL SUPPORT	1
3	5214PINE-SKIRT	WOOD STRIP	1
4	8503SCREW	STAINLESS STEEL SCREW	3
5	8513SCREW	DECORATIVE CAPS	3

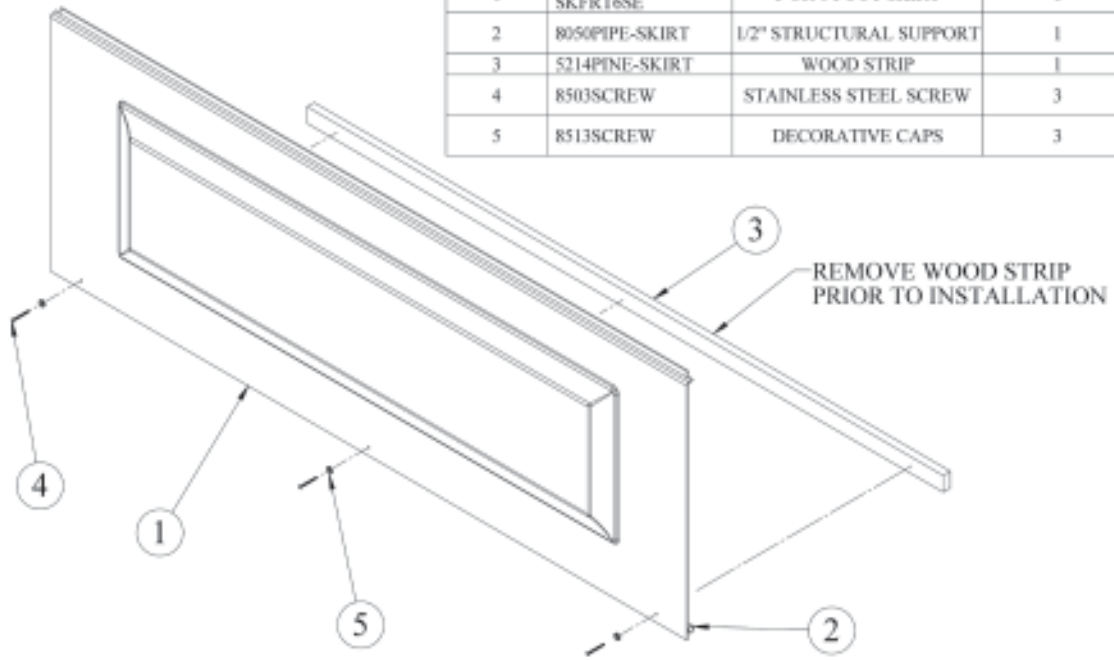

## DETAIL VIEW B

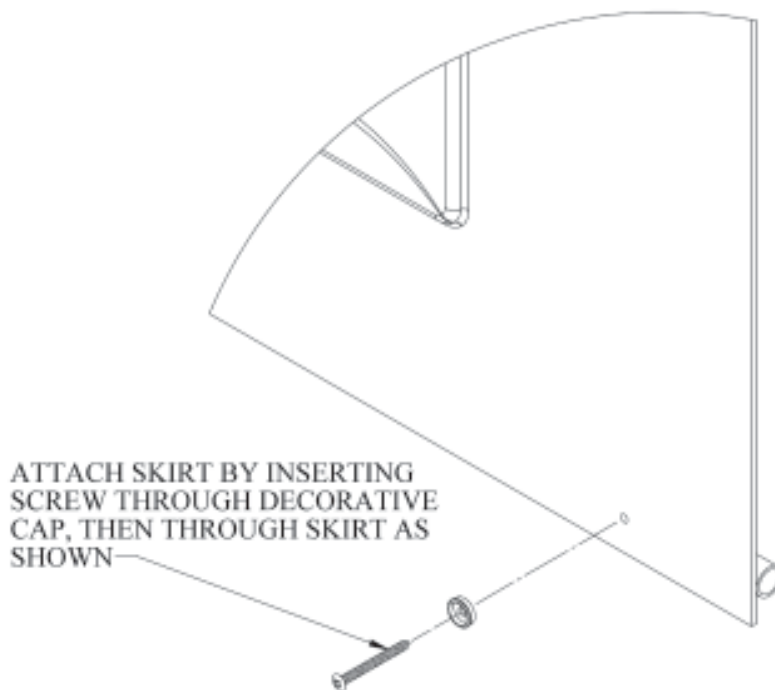

## FINAL ASSEMBLY TUB WITH METAL FRAME BASE

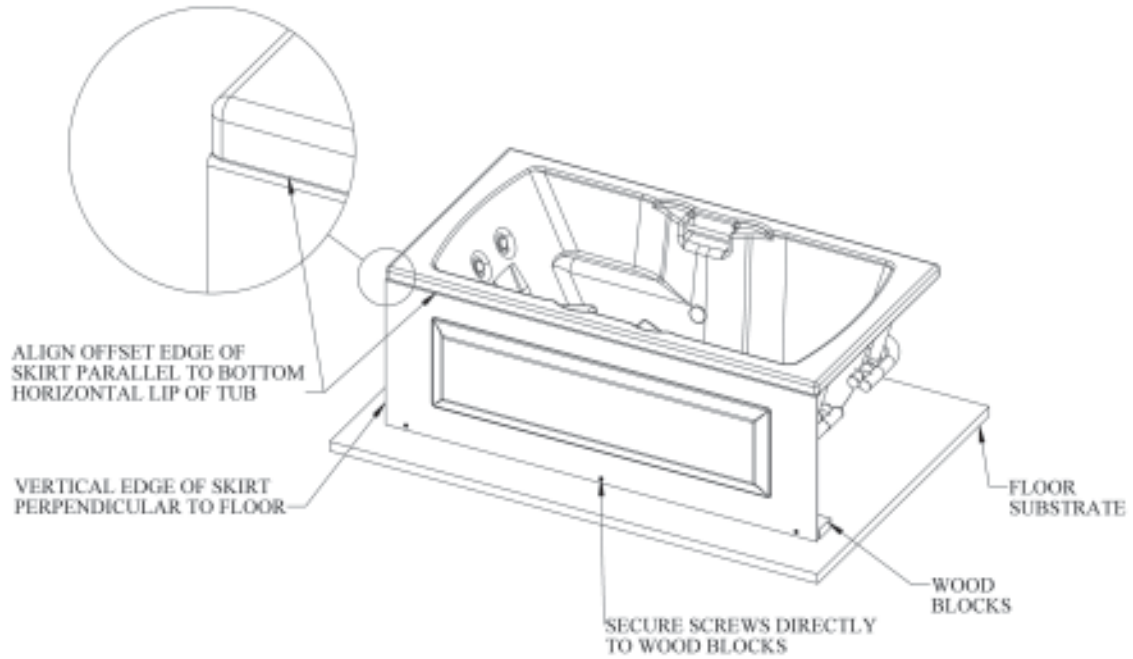

## FINAL ASSEMBLY TUB WITH ABS BASE

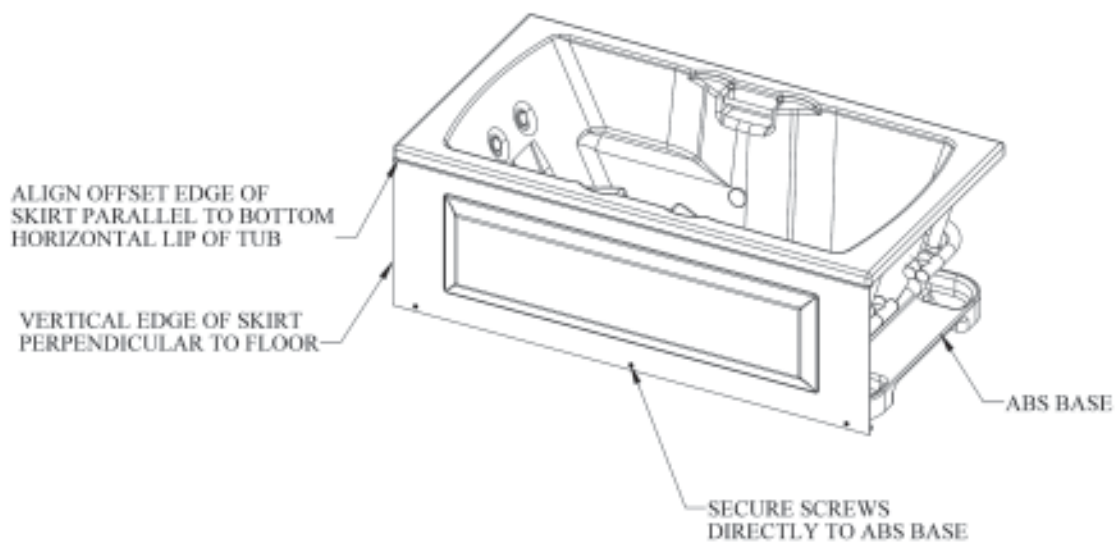

**FIGURE 1**

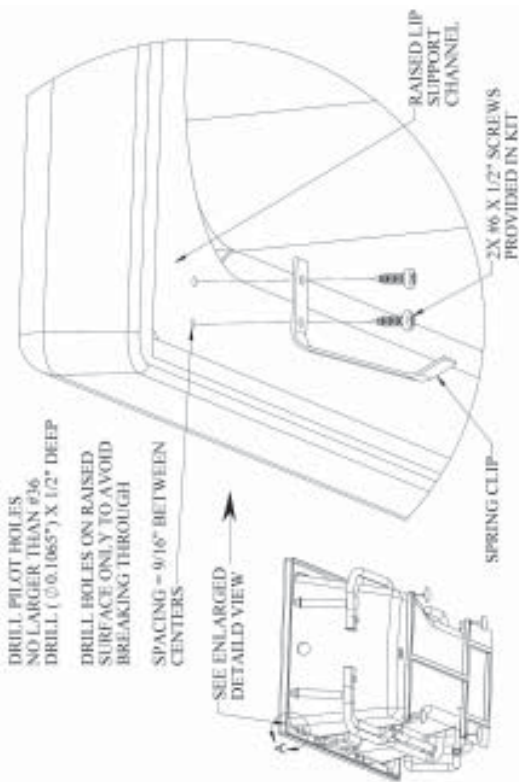

**FIGURE 2**

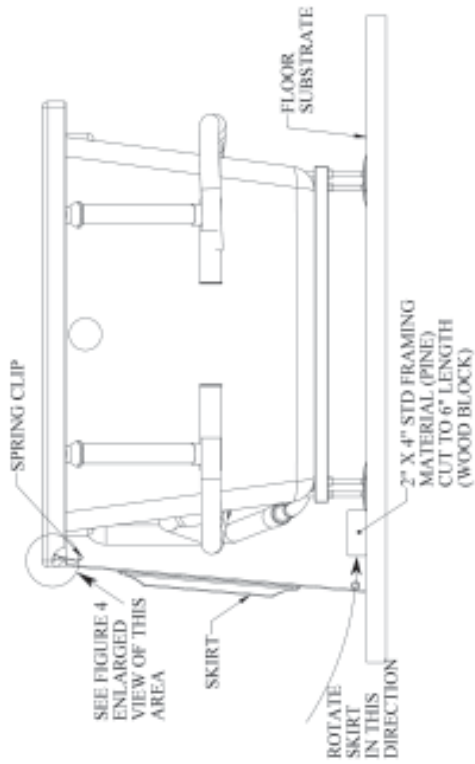

**FIGURE 3**

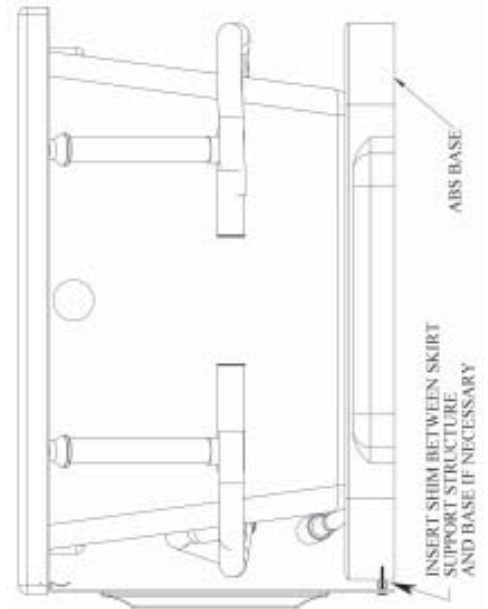

**FIGURE 4**

