

SANTA CLARA – ESTATE SERIES

inches (mm)

60 x 32 x 23 ½ (1525 x 815 x 600) • Fax on Demand #1307

LEFT DRAIN MODEL #AI6032ISL

RIGHT DRAIN MODEL #AI6032ISR



FEATURES

- 7 hydrotherapy jets: pressure-flo (4), StressEaz neck and shoulder therapy (1), recessed rotary (2)
- 1.75hp pump
- Electronic on/off control
- Deep bathing well
- Bolt-on grab bars (2): color matched (Biscuit or White), Chrome
- Sculpted armrests
- Integral skirt with removable access panels
- Integral tile flange
- Slip-resistant floor
- Pre-leveled ABS support base
- Quiet pad anti-vibration pump mount
- Left or right drain
- Lucite cast acrylic surface
- Limited lifetime warranty

AQUATIC ADVANTAGE

- National distribution
- 6 manufacturing facilities
- Private fleet
- Centralized customer service
- Field support
- 24-hour fax-on-demand

COLOR & TRIM OPTIONS

Stock	Premium
Almond (C, M)	Black (C, M)
Bone (C, M)	Cashmere (M)
Linen/Biscuit (C, M)	Mexican Sand (M)
Sterling Silver (C, M)	Red (M)
White (C, M)	Sandbar (M)

C = Color Matched Trim

M = Metallic Trim (Brushed Nickel, Chrome, Polished Brass)

OPTIONS

- Chromotherapy LED lighting
- 1.5kW inline maintenance heater
- Comfort pillow: Biscuit, Black, White
- Cable drive waste & overflow: Chrome, Oil Rubbed Bronze, Polished Brass, Brushed Nickel, Color Matched (Biscuit, Bone, White)
- Optional pump location



SANTA CLARA

60 x 32 x 23 1/2 (1525 x 815 x 600)
inches (mm)

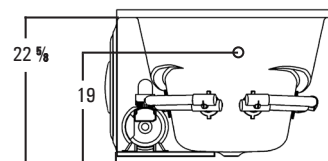
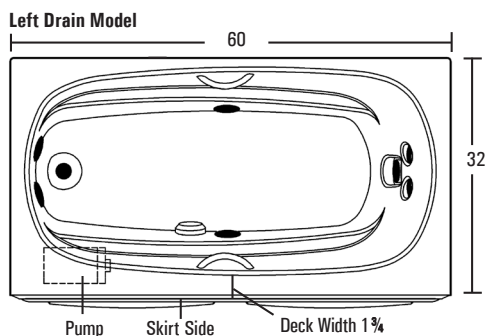
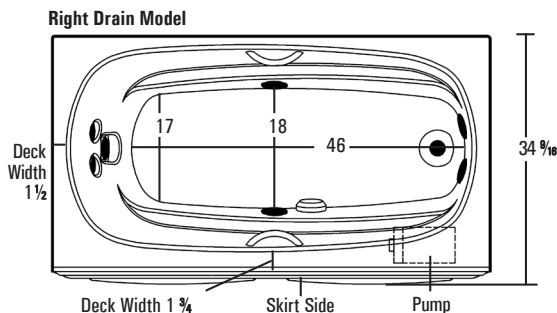

Right Drain Model

**Note: Requires a mortar base.
ABS Support Base not included.**

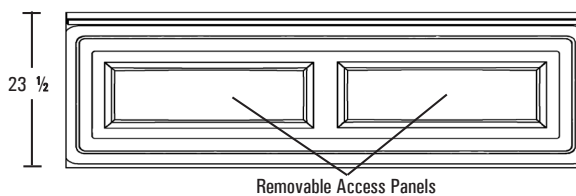

FEATURES lbs (kg) Dimensional Tolerance ± 3/8". Dimensions needed for site preparation should be measured from the unit. Aquatic assumes no responsibility for preparatory work.

Type and Model #	Material	Jets	Pump	Heater	Controls	Drain	Pkg. Wt.
Whirlpool #A16032ISL/R	Acrylic	7	1.75 HP	1.5 kw Inline (optional)	Electronic on/off	Left	135 (61)

DIMENSIONS inches (mm)

Width Overall / Net	Depth Overall / Net	Height Overall / Net	Skirt Height
60 (1525)	32 (815)	23 1/2 (600)	22 5/8 (575)

SUMP DATA inches (mm)

Capacity to Overflow gal (ltr)	Min. Operating Capacity gal (ltr)
69 (1750)	50 (189)

PLUMBING DIMENSIONS inches (mm)

A	B
1 5/8 (40)	9 1/4 (235)

ELECTRICAL DATA

Component	Specification	Requirement
Pump	1.75 HP; 12 AMP; 110 V	15 AMP; 110V, separate circuit; Class A GFCI
Optional Heater	1.5 kW; 12.5 AMP; 110 V	15 AMP; 110V, separate circuit; Class A GFCI

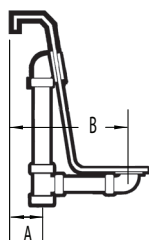

NOTES:

1) Where applicable, utilize cut-out templates packed with unit for deck cutouts.

2) 16 x 20 (405 x 510) minimum access required at pump/blower location(s).