

SAN SIMEON – ESTATE SERIES

inches (mm)

59 ½ x 37 ¾ x 20 ¼ (1510 x 960 x 510) • Fax on Demand #1306

WHIRLPOOL MODEL #AI60380

SOAKER MODEL #AI60380TO



AQUATIC ADVANTAGE

- National distribution
- 6 manufacturing facilities
- Private fleet
- Centralized customer service
- Field support
- 24-hour fax-on-demand

COLOR & TRIM OPTIONS

Stock	Premium
Almond (C, M)	Black (C, M)
Bone (C, M)	Cashmere (M)
Linen/Biscuit (C, M)	Mexican Sand (M)
Sterling Silver (C, M)	Red (M)
White (C, M)	Sandbar (M)

C = Color Matched Trim

M = Metallic Trim (Brushed Nickel, Chrome, Polished Brass)

FEATURES

- 7 hydrotherapy jets: pressure-flo (4), StressEaz neck and shoulder therapy (1), recessed rotary (2)
- 1.75hp pump
- Electronic on/off control
- Deep bathing well
- Sculpted armrests
- Slip-resistant floor
- Pre-leveled ABS support base
- Quiet pad anti-vibration pump mount
- Universal drain
- Lucite cast acrylic surface
- Limited lifetime warranty

OPTIONS

- Chromatherapy LED lighting
- 1.5kW inline maintenance heater
- Comfort pillow: Biscuit, Black, White
- Cable drive waste & overflow: Chrome, Oil Rubbed Bronze, Polished Brass, Brushed Nickel, Color Matched (Biscuit, Bone, White)
- Optional pump location



SAN SIMEON

59 1/2 x 37 3/4 x 20 1/4 (1510 x 960 x 510)
inches (mm)

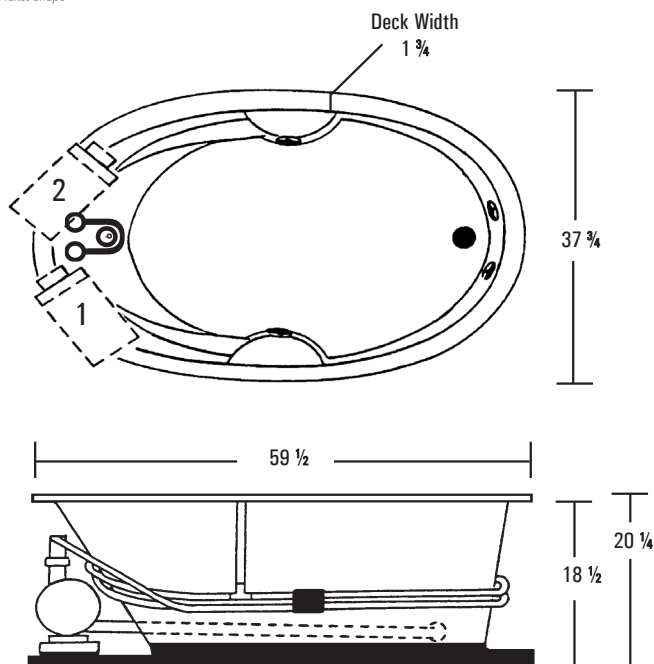

Note: Tub Only units do not come standard with the Pre-leveled ABS Support Base.

FEATURES lbs (kg) Dimensional Tolerance ± 3/8". Dimensions needed for site preparation should be measured from the unit. Aquatic assumes no responsibility for preparatory work.

Type and Model #	Material	Jets	Pump	Heater	Controls	Drain	Pkg. Wt.
Soaker #A16038OTO	Acrylic	0	-	-	-	Universal	139 (63)
Whirlpool #A16038O	Acrylic	7	1.75 HP	1.5 kw Inline (optional)	Electronic on/off	Universal	179 (81)

DIMENSIONS inches (mm)

Width Overall / Net	Depth Overall / Net	Height Overall / Net	Skirt Height
59 1/2 (1510)	37 3/4 (960)	20 1/4 (510)	-

SUMP DATA inches (mm)

Capacity to Overflow gal (ltr)	Min. Operating Capacity gal (ltr)	WIDTH @ centerline		DEPTH @ centerline	
		Top	Bottom	Top	Bottom
60 (1525)	41 (155)	51 1/2 (1310)	43 3/4 (1110)	25 1/4 (640)	21 1/2 (545)

PLUMBING DIMENSIONS inches (mm)

A	B
2 1/2 (65)	9 3/8 (240)

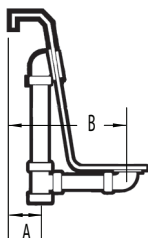

ELECTRICAL DATA

Component	Specification	Requirement
Pump	1.75 HP; 12 AMP; 110 V	15 AMP; 110V, separate circuit; Class A GFCI
Optional Heater	1.5 kW; 12.5 AMP; 110 V	15 AMP; 110V, separate circuit; Class A GFCI

NOTES:

1) Where applicable, utilize cut-out templates packed with unit for deck cutouts.

2) 16 x 20 (405 x 510) minimum access required at pump/blower location(s).